

## Clippard Instrument Laboratory, Inc.

Clippard is a family owned and operated company. There are currently six family members, second and third generation, working there. The family emphasis extends to all employees and dictates all company policies. Quality is stressed as a matter of pride and family support of co-workers. Company goals are not business school imperatives but basic family values: honesty, fairness, strength, compassion, and mutual respect. This translates to our products and customers as quality, performance, service, and value. It translates to our community as a company that supports local activities and charities, and is known as a "good place to work."



The people of Clippard have many unique talents and abilities. They have built a wealth of experience in all aspects of miniature pneumatics. The company's headquarters are located in Cincinnati, Ohio. All sales and corporate offices are housed there as well as the manufacture of valves, modules, and fittings. Clippard runs over twenty-five automatic screw machines and twelve CNC machining centers to make most of its component

parts. Some parts are also purchased from carefully selected vendors, most of which have a long term relationship with Clippard. Extensive secondary operations and assembly complete the core of manufacturing. The unique aspect is the extensive use of Clippard products on all machinery, fixtures, and jigs throughout the plant, most of which are custom made in Clippard's own shop. Clippard Minimatics® are widely used to speed and improve production. Few other manufacturers can demonstrate such an earnest commitment to the value of their own products.



In nearby Fairfield, Ohio, Clippard built a new plant in 1998 to manufacture electronic interface valves and air cylinders. Situated on 16.9 acres this facility has plenty of room for growth. In Madison, Indiana, a small subsidiary makes acrylic modular circuit subplates. The fourth Clippard facility is four thousand miles away, a sales and distribution center, Clippard Europe S.A., in Belgium.



Visitors to the Clippard plants are most impressed not just with machines and facilities, but with the people. Indeed these achievements are not accidental. Clippard has honed its policies and procedures to create a positive and efficient workplace. Things like job enrichment, cross training, safety training, process controls, individual empowerment, and continuing education opportunities have made our work-force second to none.



## Mission

The people at Clippard recognize the importance of keeping business and manufacturing thriving in a rapidly changing world economy. Today's fast-paced, industrial market demands productivity. By supplying high quality miniature pneumatic components at affordable prices, along with expert application assistance, Clippard makes the benefits of increased productivity available to everyone.

## Markets Served

Clippard's worldwide distributor network has grown to include offices in 30 countries and throughout the U.S., providing quality components for an unlimited list of applications. From a simple two step machine process, to complex automation of sophisticated machinery, Clippard Minimatrics are used virtually everywhere for control, interface, sensing, logic, and actuation functions. This broad range of applications spans a variety of industries including: machinery, packaging, textiles, medical equipment, animation, agriculture, material handling, mobile equipment, assembly, recreation, electronics, food processing, coatings, security, chemicals, construction, testing, mining, and many more.

## History

Leonard Clippard founded Clippard Instrument Laboratory in 1941, (Inc., 1946). The initial product line consisted of electronic test equipment and radio frequency coils. The manufacturing of these products required machinery employing the use of small, yet powerful, pneumatic cylinders and valves. Since no such products were commercially available, Leonard Clippard designed and built his own. Because the need for these components was widespread, particularly in manufacturing automated fixturing, Clippard presented them as a new product line in 1949. Until his retirement in 1977, Leonard Clippard continued to be a pioneer in miniature pneumatic components. Today, the company is managed by William L. Clippard, III, president and Robert L. Clippard, vice-president; the Minimatic line has grown to include over 5,000 standard products.



## Product Lines

Some of the many products offered include Minimatic® valves, cylinders, fittings, modular components, push buttons, stainless steel cylinders, electronic manifold cards, circuit analyzers, and prepiped circuit manifold subplates. Special components designed for customer's OEM applications are also available.



## Quality

Quality remains a primary feature with every product Clippard produces. This is achieved through the excellence in manufacturing practices and craftsmanship that has continued throughout the years. The high standards set by Leonard Clippard, in company relationships with customers, distributors, suppliers. And employees continue to be upheld. The company motto, "Quality People, Quality Products," emphasizes the important role every employee plays in maintaining the company's reputation.

## Distribution

A fully-trained, professional distributor network markets and supports Clippard products, worldwide. To assure quality performance, close customer contact is maintained through a network of over 100 stocking distributors, with over 800 fluid power specialists. Clippard maintains close ties with these distributors through special conferences, training seminars, and the complete support of the factory sales and service team.



The components needed to manufacture and construct pneumatic logic control circuits are readily available, reliable and have been proven in countless applications.

The symbols needed to design a pneumatic circuit are few, yet until now no practical rapid symbology for the control designer existed. Most of the symbols available to the designer are too complex to facilitate clear, creative thinking, take too long to record, leave room for significant errors, and generally slow down the design process.

In an effort to improve both the speed and accuracy of creative design, we offer for your consideration and use this simplified system of symbols for designing pneumatic control circuitry.

### Basic Requirements

Before a circuit can be designed, one needs a basic understanding of the various components available and how they function. This understanding is a requirement for the successful use of any symbol. To depict these functional concepts, graphic symbols are used.

Historically, pneumatic symbols have been overly detailed and cumbersome. Symbols (such as ANSI) are often used to tell a complete narrative story. The symbols of this type are difficult to use because of their complexity. The writing and the reading of them is always lengthy, robbing time from creative efforts. As a finished product they are useful, and tell a great deal about the component, pertinent or otherwise, but they were never intended for air logic control designs. To a circuit designer such symbols are a burden that can slow or derail the thought process.

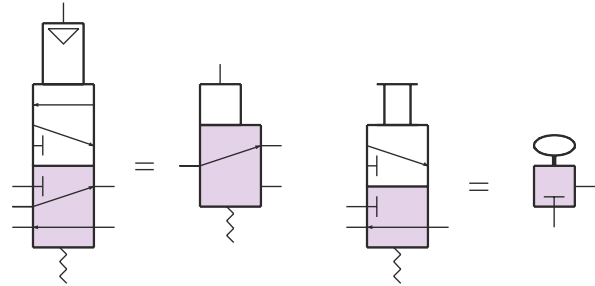

### Time-saving

What is needed is a group of pneumatic component symbols that will provide the circuit designer, both novice and professional, with a viable shorthand that will save time, yet clearly record and communicate ideas. They should be open-ended and expandable to truly represent the variety of pneumatic controls available to the designer now, as well as in the future.

### Fast and Functional

They must be fast and easy to draw. They should be both pictorial and functional in nature to help the designer visualize the circuit, and to provide the necessary pertinent information about how components work (inputs, output, actuators, etc.). What follows is a basic set of symbols designed to meet these criteria. They have proven to be fast and informative in years of daily use. These symbols are recommended for anyone with a basic understanding of pneumatic control components' functions, and who seeks to design in a useful and productive manner.

*Simplified symbols for faster, easier and more creative pneumatic circuit design.*

## Basic Symbol Groups

Figure 1

Basic Symbols	Actuators	Button	Toggle	Cam Follower	Solenoid	Single Pilot	Double Pilot	Double Pilot Spring Biased

Valves	
3-Way N.C. Valve	
3-Way N.O. Valve	
3-Way Selector Valve	
3-Way Diverter Valve	
4-Way Valve	
5-Ported 4-Way Valve	

Directional valves comprise the largest portion of any air logic circuit. Complete directional valve symbols are created by combining the appropriate actuator and valve symbols found along the horizontal and vertical edges of the chart (Figure 1 and Figure 2).

Seven of the most commonly used actuators are shown in Figure 1. The designer is free to extend this list as may be required to suit a particular need.

A close study of most air logic control circuits will reveal that there are only six basic valve functions commonly used. The symbols for these valve functions are shown in Figure 2. These six basic valve symbols, when combined with the basic actuator symbols, comprise virtually all the directional valve symbols needed for air logic control.

Figure 3 gives a flow path explanation for the basic valve symbols. Accessory components are designed for a specific purpose. The valves included in accessory components are basically flow devices that alter flow paths or signals, but do not generate signals by themselves. Simplified symbols for accessory components are, for the most part, self explanatory and are shown at the bottom of page 358.

A brief review of the valves, their actuators, and how they combine into useful symbols, together with the examples contained in the following pages, will give the reader a valuable, time-saving method for drawing air logic control circuits.

Figure 2

## Basic Valve Flow Paths

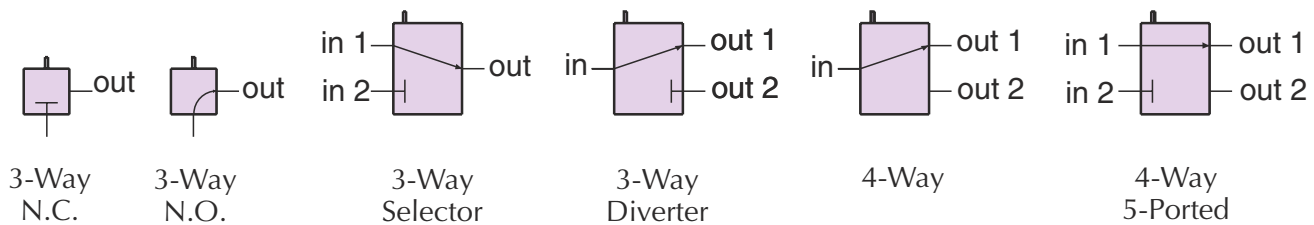
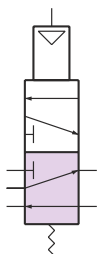

Figure 3

## Symbols created by combining valves and actuators

Basic Symbols		Actuators	Button	Toggle	Cam Follower	Solenoid	Single Pilot	Double Pilot	Double Pilot Spring Biased
Valves									
3-Way N.C. Valve									
3-Way N.O. Valve									
3-Way Selector Valve									
3-Way Diverter Valve									
4-Way Valve									
5-Ported 4-Way Valve									

## Derivation of Simplified Symbol from ANSI



ANSI

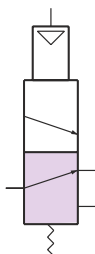

1. Exhaust flow paths removed

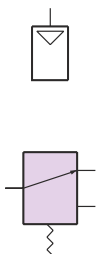

2. Eliminate redundant block

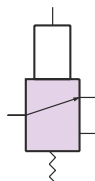

3. Remove unnecessary notation

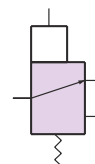

4. Relocate pilot for faster drawing and recognition

The 4-way valve is a key component in air circuitry. Shown above is the simplification process with the 4-way valve. Not every simplified symbol will be directly related to its corresponding ANSI symbol.

## Rules to help guide application

A few simple rules in applying these air logic control symbols are as follows:

**1. Symbols are always drawn in the valve's normal unactuated position** - not as held at the start of a cycle or as actuated. The flow direction or condition of the valve's inlet is in its normal position. The symbol does not change, even if the valve is shown as actuated. To change the symbol would change the type of valve shown in the circuit.

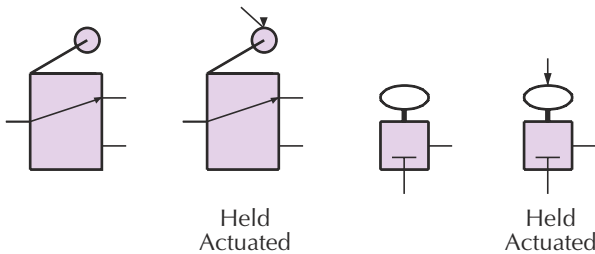

Figure 4

**2. Symbols do not show exhaust flow paths.**

Nearly all air logic circuit components exhaust to atmosphere, and exhaust flow paths are of little or no importance in understanding a pneumatic control circuit. It is implied that all directional valves have their output either connected to their input or to atmosphere.

**3. In all symbols the valve is assumed to have a spring returning it to its normal condition unless otherwise shown.** Remember, more than one type of actuator can be shown on opposite ends of the valve.

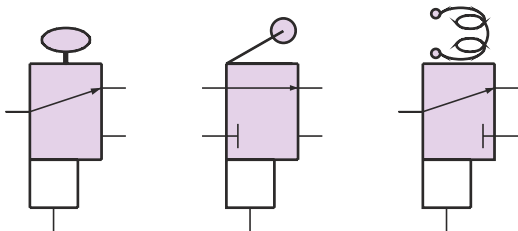

Figure 5

**4. Actuators are understood to push the flow path indicator when actuated, pushed or energized.** Since the methods of actuating air logic valves are nearly limitless, the circuit designer may create additional actuator symbols to represent a special requirement.

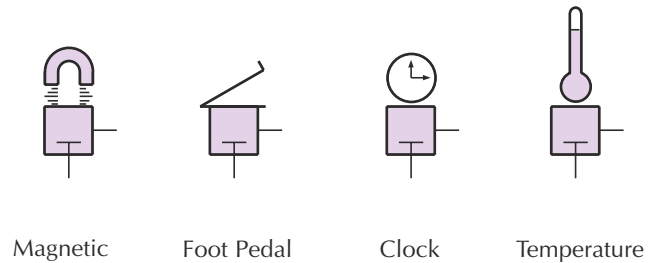

Figure 6

**5. Circuits should not be burdened with excessive supply lines.** Supplies are shown at each component requiring one. Subscripts are used to identify different supplies, such as different pressures or medias.

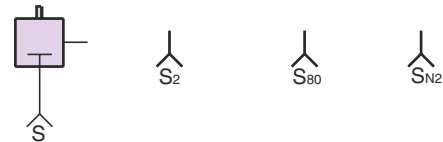

Figure 7

**6. Special valve symbols may be constructed by the user or multiple symbols may be tied together and indicated as one component.**

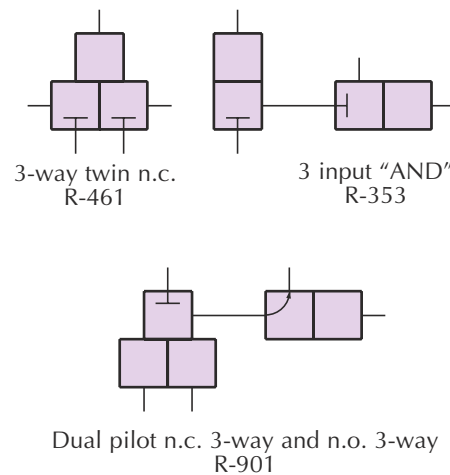

Figure 8

**7. In some specialized components more than one actuator (usually the same type) can be put on a valve.**



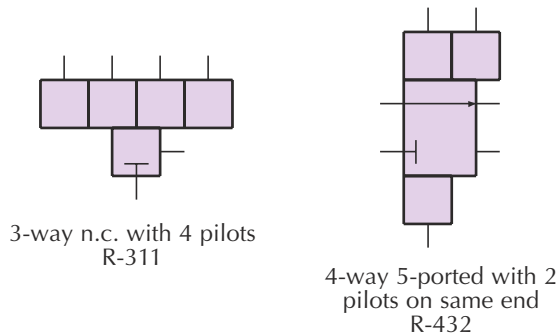

Figure 9

**8. 2-way valves are seldom used in air logic circuits but on those occasions where a 2-way valve is needed the 3-way valve symbol can be used, with an appropriate notation as to its function in the circuit such as shown in figure 10.**

### Easy to draw

The simplified air logic control symbols are easy to draw and use. They are readily drawn freehand with only one line width, and no dashed or dotted lines. They are proportioned for fast layout on plain or blocked paper and can be scaled up or down as needed. Figure 11 shows a plan for proportions of various elements.

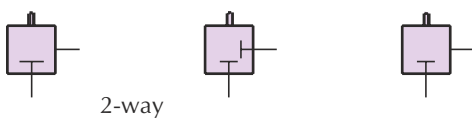

Figure 10

**The 3-way N.O. valve in figure 12 is the same regardless of how it is oriented or whether the outlet is to the right or left. Free orientation of symbols allows clarity in drawing circuits, minimizing design time spent on layout and in drawing.**

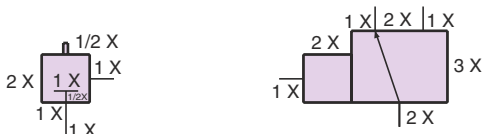

Figure 11

### System Benefits

The system of simplified symbols shown here provides:

1. A method that is fast and quick to draw or recognize.
2. A group of symbols flexible enough to depict 98% of air logic control circuit designs.
3. A method simple enough for all designers to quickly learn and use to their benefit.
4. A method universal enough to further the use of air logic valves and controls of any manufacture.
5. A symbology that is open-ended and logical, and reflects the entire variety of pneumatic control components available today.
6. A system that is expandable to include new components available now or in the future.

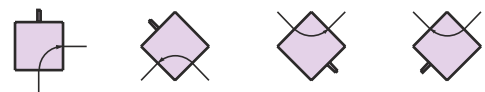

Figure 12

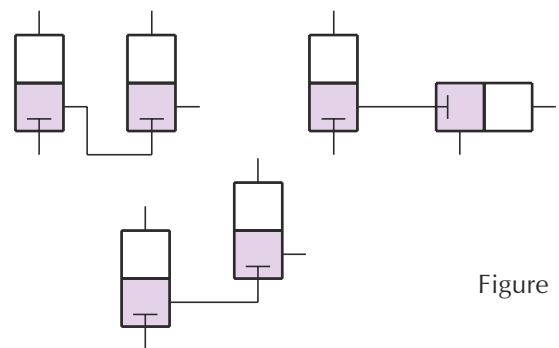

Figure 13

### Versatile

It should be emphasized that the simplified symbols provided here are intended as a design aid, and may or may not be used to replace other formal symbologies for finished drawings. They are applicable to components of any manufacture as long as the component gives the same function.

## Comparisons to Existing Symbols

It may be helpful to understand the useful simplicity of these new symbols by comparing them to existing symbology now in use.

Shown below are air circuits using existing symbols for various types of valves, and the same circuits using the simplified symbols provided in this new method. The more complex symbols involve considerable time in drawing them. Many of the symbols are so closely alike as to cause confusion in understanding what is meant. Simplified symbols help eliminate this confusion.

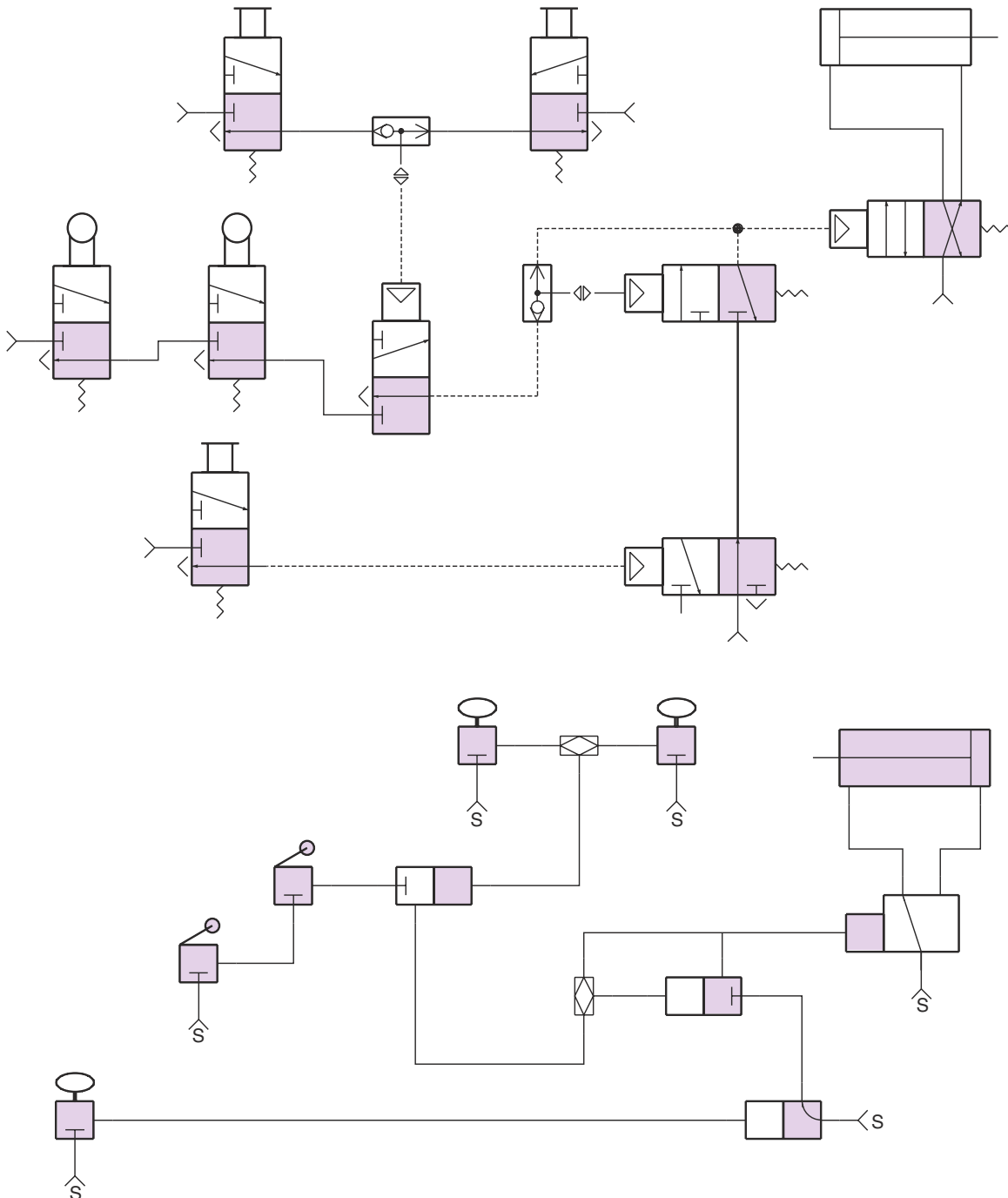

Figure 14



## Comparisons to Existing Symbols

A few moments review of the comparisons will quickly reveal that the new simplified symbols provide an important aid for speed in designing new circuits. In air logic design where drawing time needs to be kept to a minimum, the new simplified symbols offer the designer new freedom to spend his time in the creative aspects of the task, rather than in the time-consuming details of excessive drawing.

On the next page is reproduced a complete chart of the basic valves, actuators, combinations and the auxiliary components used in pneumatic logic control circuitry.

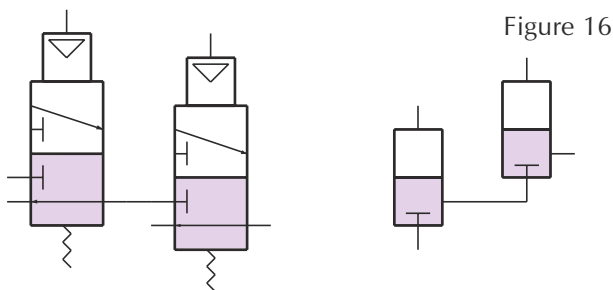
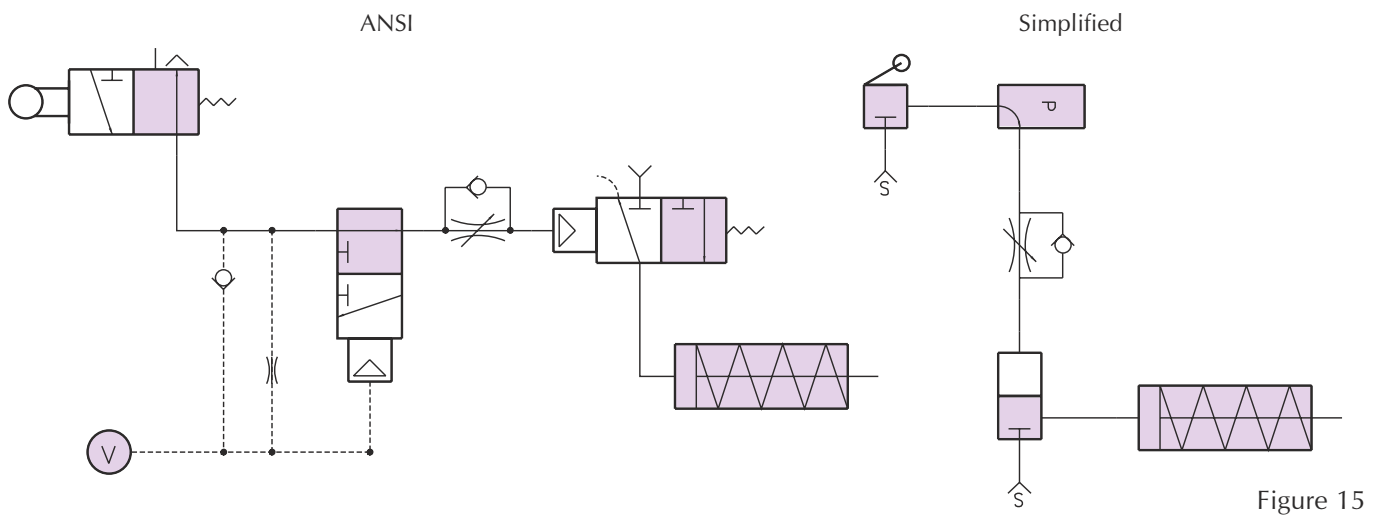

AND A and B gives output D

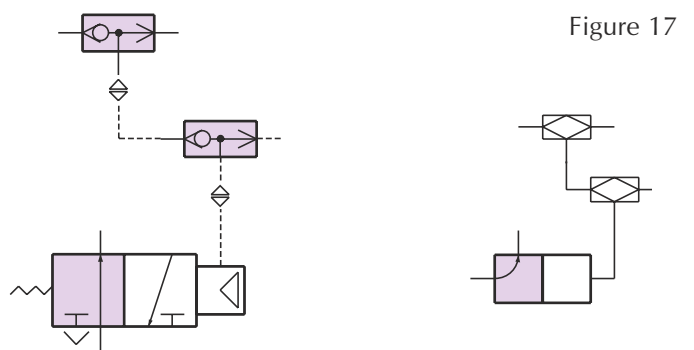

NOR C or D or E stops output B

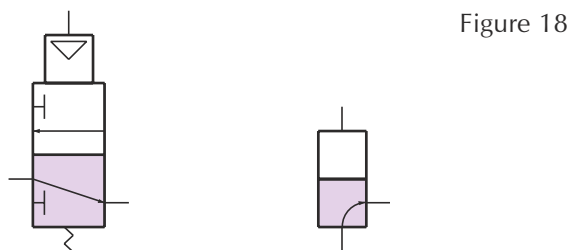

NOT C stops output B

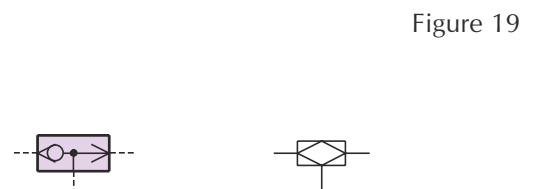

OR A or B = C

Basic Symbols		Actuators	Button	Toggle	Cam Follower	Solenoid	Single Pilot	Double Pilot	Double Pilot Spring Biased
Valves									
3-Way N.C. Valve									
3-Way N.O. Valve									
3-Way Selector Valve									
3-Way Diverter Valve									
4-Way Valve									
5-Ported 4-Way Valve									

Pulse Valve	Shuttle Valve	Flow Control	Check Valve	Needle Valve	Pressure Regulator	Whisker Valve	Pilot Sensor	Volume Tank
Double Acting Cylinder	Single Acting Cylinder	Pressure Gauge	Quick Connect	Line Connecting	Line Crossing	Supply	Air Actuated Electric Switch	Totalizer



## Length

To Convert		inch	To	millimeter	Multiply By		25.40	
		millimeter		inch			.03937	
in	mm		in	mm	in	mm	in	mm
0.025	0.635		0.275	6.985	0.525	13.335	0.775	19.685
0.050	1.270		0.300	7.620	0.550	13.970	0.800	20.320
0.075	1.905		0.325	8.255	0.575	14.605	0.825	20.955
0.100	2.540		0.350	8.890	0.600	15.240	0.850	21.590
0.125	3.175		0.375	9.525	0.625	15.875	0.875	22.225
0.150	3.810		0.400	10.160	0.650	16.510	0.900	22.860
0.175	4.445		0.425	10.795	0.675	17.145	0.925	23.495
0.200	5.080		0.450	11.430	0.700	17.780	0.950	24.130
0.225	5.715		0.475	12.065	0.725	18.415	0.975	24.765
0.250	6.350		0.500	12.700	0.750	19.050	1.000	25.400

## Flow

To Convert		cfm (cubic ft/min.)	To	L / min (liters/min.)	Multiply By		28.317	
		L / min (liters/min.)		cfm (cubic ft/min.)			.03531	
cfm	L / min		cfm	L / min	cfm	L / min	cfm	L / min
0.5	14.159		5.5	155.744	10.5	297.334	16.0	453.07
1.0	28.317		6.0	169.903	11.0	311.493	17.0	481.39
1.5	42.476		6.5	184.062	11.5	325.652	18.0	509.71
2.0	56.634		7.0	198.221	12.0	339.811	19.0	538.02
2.5	70.793		7.5	212.380	12.5	353.970	20.0	566.34
3.0	84.951		8.0	226.539	13.0	368.129	21.0	594.66
3.5	99.110		8.5	240.698	13.5	382.288	22.0	622.97
4.0	113.268		9.0	254.857	14.0	396.447	23.0	651.29
4.5	127.427		9.5	269.016	14.5	410.606	24.0	679.61
5.0	141.585		10.0	283.175	15.0	438.924	25.0	707.93

## Pressure

To Convert		psi (lbs/sq.inch)	To	bars	Multiply By		14.50	
		bars		psi (lbs/sq.inch)			.06895	
psi	bars		psi	bar	psi	bars	psi	bars
2.5	0.17		27.5	1.90	52.5	3.62	77.5	5.34
5.0	0.34		30.0	2.07	55.0	3.79	80.0	5.52
7.5	0.52		32.5	2.24	57.5	3.96	82.5	5.69
10.0	0.69		35.0	2.41	60.0	4.14	85.0	5.86
12.5	0.86		37.5	2.59	62.5	4.31	87.5	6.03
15.0	1.03		40.0	2.76	65.0	4.48	90.0	6.21
17.5	1.21		42.5	2.93	67.5	4.65	92.5	6.38
20.0	1.38		45.0	3.10	70.0	4.83	95.0	6.55
22.5	1.55		47.5	3.28	72.5	5.00	97.5	6.72
25.0	1.72		50.0	3.45	75.0	5.17	100.0	6.90



# CONVERSION FACTORS

## Force

To Convert		pounds (lbs)	To	newtons (N)	Multiply By		4.448
					newtons (N)	pounds (lbs)	
lbs	N	lbs	N	lbs			N
0.25	1.1	2.75	12.2	5.25	23.4	7.75	34.5
0.50	2.2	3.00	13.3	5.50	24.5	8.00	35.6
0.75	3.3	3.25	14.5	5.75	25.6	8.25	36.7
1.00	4.4	3.50	15.6	6.00	26.7	8.50	37.8
1.25	5.6	3.75	16.7	6.25	27.8	8.75	38.9
1.50	6.7	4.00	17.8	6.50	28.9	9.00	40.0
1.75	7.8	4.25	18.9	6.75	30.0	9.25	41.1
2.00	8.9	4.50	20.0	7.00	31.1	9.50	42.3
2.25	10.0	4.75	21.1	7.25	32.2	9.75	43.4
2.50	11.1	5.00	22.2	7.50	33.4	10.00	44.5

## Temperature

To Convert		Fahrenheit (°F)	To	Celsius (°C)	Multiply By		$(°F - 32) / 1.8$
					Celsius (°C)	Fahrenheit (°F)	
°F	°C	°F	°C	°F			°C
5	-15.0	55	+12.8	105	+40.6	155	68.3
10	-12.2	60	15.6	110	43.3	160	71.1
15	-9.4	65	18.3	115	46.1	165	73.9
20	-6.7	70	21.1	120	48.9	170	76.7
25	-3.9	75	23.9	125	51.7	175	79.4
30	-1.1	80	26.7	130	54.4	180	82.2
35	+1.7	85	18.9	135	57.2	185	85.0
40	+4.4	90	32.2	140	60.0	190	87.8
45	+7.2	95	35.0	145	62.8	195	90.6
50	+10.0	100	37.8	150	65.6	200	93.3